

OSO

2024

Charge Smartcontrol Saga S - Saga SX water heaters

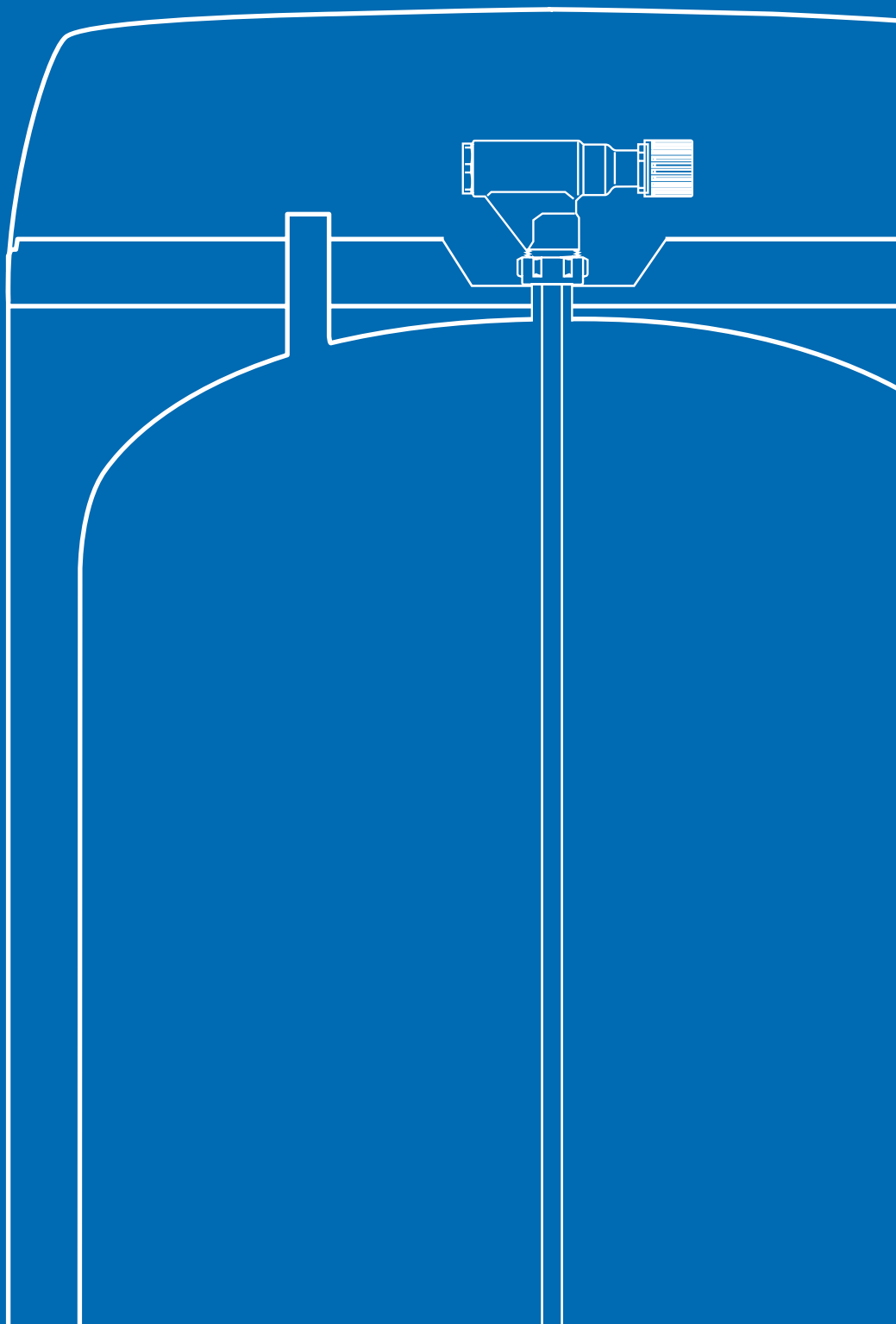

CHARGE - R2.2

Smartcontrol for SAGA* water heaters

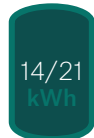

PRICE OPTIMIZATION

Automatic price optimisation towards time of use tariffs (TIU) in Canada, ensuring heating of the water when energy price is low.

FLEET CONTROL

The OSO Charge predicts the energy consumption and allows you to adjust the simultaneous load off your fleet days ahead.

AI - MACHINE LEARNING

Charge uses AI (artificial intelligence) to learn the hot water usage patterns in the home to ensure hot water is always available.

SLEEP MODE

Tell your water heater when you are going away, and it will use as little power as possible. Charge will heat up the water one day before you return to your home.

INSIGHT

See how much hot water is available at any given time, shown as capacity in no. of showers or baths.

HISTORIC USAGE OVERVIEW

Full overview of power consumption during the last 7 days.

SAFETY

Several layers of safety both in software and hardware. Built-in frost prevention safety.

*OSO CHARGE is suitable for use with OSO Saga S and Saga Xpress SX series water heaters.

ADVANTAGES

- Built-in legionella- and frost prevention
- Can be integraten in smarhouse-systems through open API
- Full control with OSO InCharge-app
- Norwegian quality, several layers of built-in safety
- CSA certified.

COMPONENTS

El. installation:	Min. 10A (2kW) / 15A (max. 3kW)
Communication:	WiFi 2,4 and 5 GHz, IEEE 802.11 b/g/n
Configuration:	Bluetooth LE
Standards:	IEC 60730 and EN 60335
Splash protection:	IP 44
User interface:	OSO inCharge App / Open API

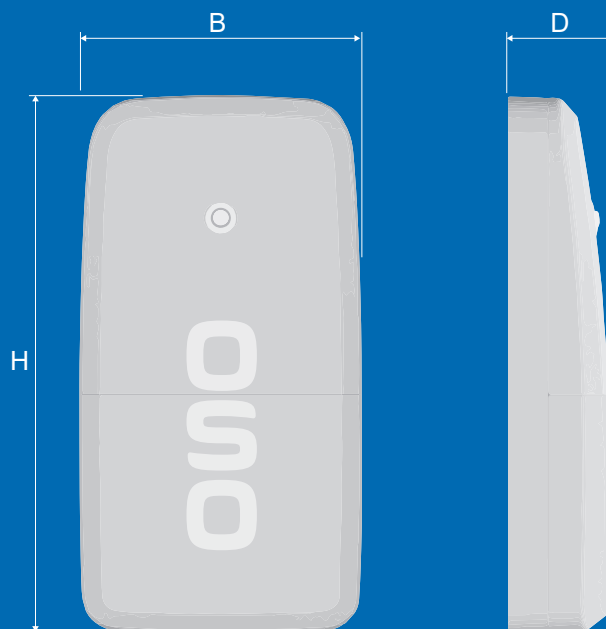

TECHNICAL DATA

OSO product no.	Product code:	H x W x D mm.	Cap. pers.	Weight kg.	Sensor dimension
11008781	Charge R2.2 - 16A/1x230V white*	315x167x62	-	0.9	-
11008768	Charge Temp. sensor 200L	L=832	-	0.6	G1/2" M
11008760	Charge Temp. sensor 300L	L=1282	-	0.8	G1/2" M

*OSO Charge requires a Temp. sensor for the correct volume water heater to function.

CHARGE - R2.2

Full control with the OSO InCharge app



OSO inCharge

- OSO InCharge app offers full control:
- Full overview of power consumption during the last 12 months
 - Available capacity and temperature in the water heater
 - Sleep mode when travelling
 - Supports multiple Charge units.



OSO Charge fitted with SAGA S 200 water heater.



OSO Charge fitted with SAGA Xpress SX 200 water heater.



SAGA – S

Unbeatable performance and pioneering design



SAGA series can be installed anywhere thanks to its pioneering design features, covering all pipings and connections. SAGA has been developed with high grade material selection and intelligent technical solutions exclusive to OSO. SAGA boasts class-leading insulation capabilities resulting in considerable energy savings, while maintaining a higher temperature than others (75°C) for unbeatable performance and more hot water in a smaller unit.

SAGA—S is suitable for most hot water requirements and comes standard with ultra-grade INCOTEC immersion heater factory fitted.

SAGA has been developed for the Canadian market with high grade material selection and intelligent technical solutions exclusive to OSO.

ADVANTAGES

- Reduces heat loss by 300 kWh*/year with NANOPUR*
 - Higher temperature and optimal design gives up to 20 % more hot water
 - 7 year warranty on the stainless steel pressure tank
- *Compared to 200 L cylinder with EPS insulation*

COMPONENTS

Thermostat	Adjustable 60-90°C - Preset 75°C
P&T valve	9 bar/99°C - 3/4" outlet to drain
Appliance feet	Adjustable - Factory fitted

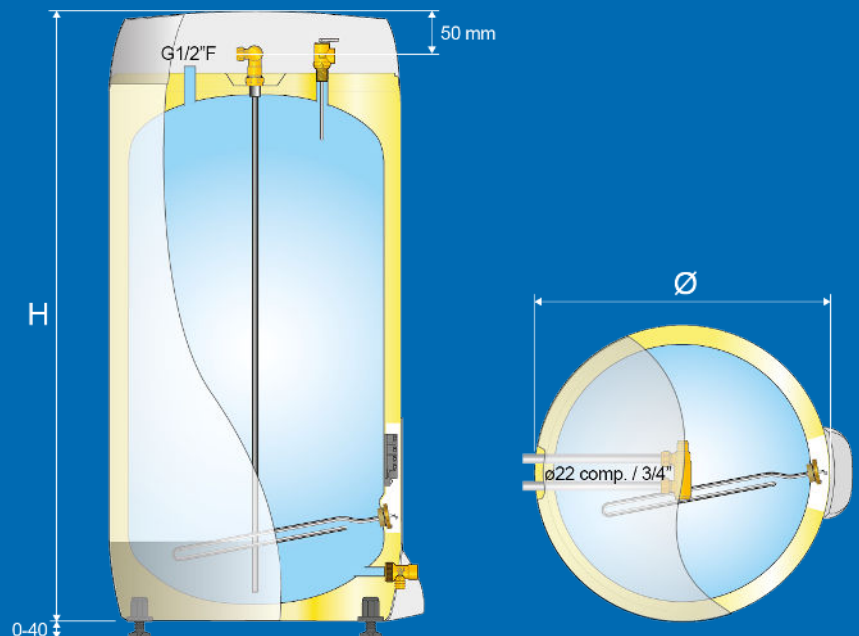

TECHNICAL DATA

Prod. no.	Product code:	Dia x Height mm.	Cap. pers.	Weight kg.	Freight vol. m ³	Actual vol. L	Actual vol. USG	Volume L/40°C	Heat loss W	Temp. setting°C
11003384	S 150 - 3 kW/1x240V	Ø570x830	2.5	29	0.32	143	37.8	190	47	75
11011284	S 200 - 3 kW/1x240V	Ø570x1260	3.5	39	0.47	194	51.2	355	66	75
11012064	S 200 - 4.8 kW/1x240V	Ø570x1260	3.5	39	0.47	194	51.2	355	66	75
11012065	S 300 - 3 kW/1x240V	Ø570x1710	5.5	51	0.63	280	73.9	539	86	75
11012066	S 300 - 4.8 kW/1x240V	Ø570x1710	5.5	51	0.63	280	73.9	539	86	75

SAGA XPRESS – SX

Hot water 3 x faster than standard hot water tanks



SAGA series can be installed anywhere thanks to its pioneering design features, covering all pipings and connections. SAGA has been developed with high grade material selection and intelligent technical solutions exclusive to OSO. SAGA boasts class-leading insulation capabilities resulting in considerable energy savings, while maintaining a higher temperature than others (75°C) for unbeatable performance and more hot water in a smaller unit.

SAGA XPRESS—SX is suitable for households with considerable hot water demands and limited space for installation. SX makes hot water available 3× faster than standard hot water tanks, without increased energy consumption thanks to flip-flop function between the immersion heaters. SX increases performance, saves installation space and comes standard with ultra-grade INCOTEC immersion heaters factory fitted.

SAGA has been developed for the Canadian market with high grade material selection and intelligent technical solutions exclusive to OSO.

ADVANTAGES

- Reduce heat loss by 300 kWh* /year with NANOPUR*
 - Hot water 3 x faster than standard hot water tanks
 - Higher temperature and optimal design gives up to 20 % more hot water
 - 7 year warranty on the stainless steel pressure tank
- *Compared to 200 L cylinder with EPS insulation

COMPONENTS

Thermostat	Adjustable 60-90°C - Preset 75°C
P&T valve	9 bar/99°C - 3/4" outlet to drain
Appliance feet	Adjustable - Factory fitted

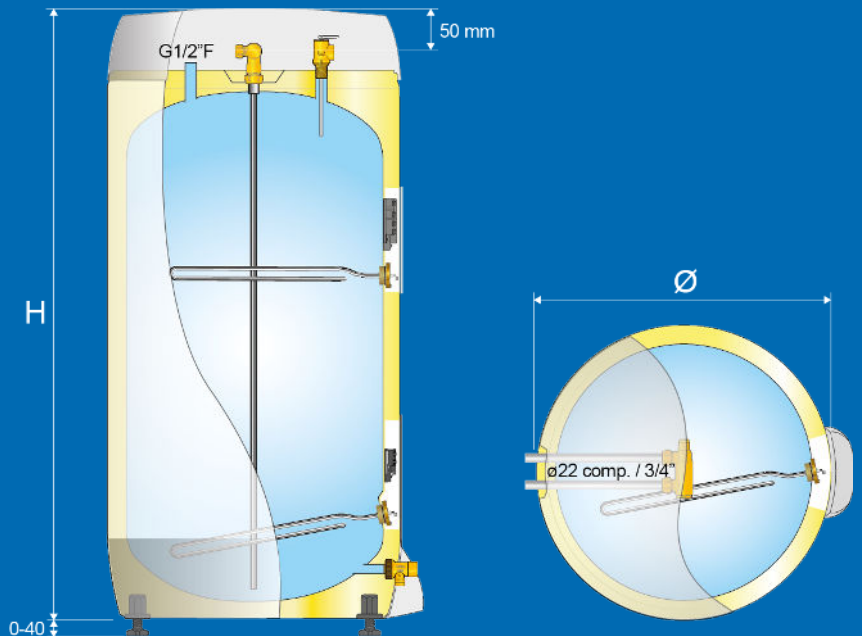

TECHNICAL DATA

Prod. no.	Product code:	Dia x Height mm.	Cap. pers.	Weight kg.	Freight vol. m ³	Actual vol. L	Actual vol. USG	Volume L/40°C	Heat loss W	Temp. setting°C
11010782	SX 150 - 4.8+(4.8)kW/1x240V	Ø570x1010	3.5	31	0.39	143	37.8	190	53	75
11012067	SX 200 - 3+(3)kW/1x240V	Ø570x1260	4.5	39	0.47	194	51.2	355	65	75
11010762	SX 200 - 4.8+(4.8)kW/1x240V	Ø570x1260	4.5	39	0.47	194	51.2	355	65	75
11012068	SX 300 - 3+(3)kW/1x240V	Ø570x1710	6.5	51	0.63	280	73.9	539	85	75
11010778	SX 300 - 4.8+(4.8)kW/1x240V	Ø570x1710	6.5	51	0.63	280	73.9	539	85	75

MARKET LEADING MANUFACTURER STAINLESS STEEL

THE FOUNDATION

Founded in 1932 by Mr. Braathen, a blacksmith and air force lieutenant, OSO was the first manufacturer of water heaters in Norway. After merely 10 years in operation more than 100 people worked at OSO. His inventiveness led to the creation of Europe's very first stainless steel water heater in 1965. Since then, more than 4 million OSO heaters has found their way to European homes.



OF WATER HEATERS



THE FUTURE

Today, OSO Hotwater is still a family business after three generations of hard work. Dedicated to improving our products and processes, we are proud to represent the most robotized manufacturing plant in Norway. The pioneering spirit continues with product innovations featuring integrated solutions, ground-breaking material technology and added value for our customers.

OSO

Market leading water heaters since 1932