

Delta Coil - DC

Volumes: 30-40-50-75-100-119 USG / 120-150-200-300-380-450 L.

EN



SAFETY INFORMATION
INSTALLATION MANUAL
O&M INFORMATION

Manufactured by OSO Hotwater AS
Industriveien 1 - 3300 Hokksund - Norway
Tel: +47 32 25 00 00 / E-mail: oso@oso.no
www.osohotwater.com

11015819-00 - 03-2026

OSO
HOT WATER

CONTENTS

1. Safety instructions	3
1.1 General information.....	3
1.2 Safety instructions for users.....	4
1.3 Safety instructions for installers	4
1.4 Installation restrictions	4
2. Product description	5
2.1 Product identification	5
2.2 Intended use	5
2.3 Technical data	5
2.4 Supplied safety equipment	5
3. Installation instructions	6
3.1 Products covered by these instructions ..	6
3.2 Included in delivery - 030/120-100/380 ...	6
3.3 Product dimensions - 030/120-100/380 ..	6
3.4 Included in delivery - 119/450	7
3.5 Product dimensions - 119/450	7
3.6 Requirements for installation location	9
3.7 Pipe installation - 030/120-100/380	10
3.8 Pipe installation - 119/450	11
3.9 Installation of center support foot.....	12
4. Initial commissioning	13
4.1 Filling with water	13
4.2 Control points.....	13
4.3 Emptying of water.....	13
4.4 Handover to end-user	13
5. User Guide	13
5.1 Annual inspection	13
5.2 Maintenance	13
6. Troubleshooting	14
6.1 Faults and fixes.....	14
6.2 Contact details - installer	14
7. Warranty conditions	15
7.1 Warranty and registration	15
7.2 Customer service.....	15
8. Removing the product	15
8.1 Removal.....	15
8.2 Returns scheme	15





1. SAFETY INSTRUCTIONS

1.1 General information

- Read the following safety instructions carefully before installing, operating, maintaining, servicing or adjusting the buffer tank.
- Personal injury or material damage may result if the product is not installed or used in the intended manner. Read and understand the entire manual before attempting installation, startup or service.
- Keep this manual and other relevant documents where they are accessible for future reference.
- The manufacturer assumes compliance (by the end-user) with the safety, operating and maintenance instructions supplied and (by the installer) with the fitting manual and relevant standards and regulations in effect at the date of installation.



Symbols used in this manual:

 WARNING	Could cause serious injury or death
 CAUTION	Could cause minor or moderate injury or damage to property
 DO NOT	DO NOT
 DO	DO

CAUTION

- * The heat-transfer medium must be water or other nontoxic fluid having a toxicity rating or Class of 1, as listed in Clinical Toxicology of Commercial Products, 5th Edition.
- * The boiler water pressure must be limited to a maximum of 30 psi by an approved safety or relief valve.

WARNING



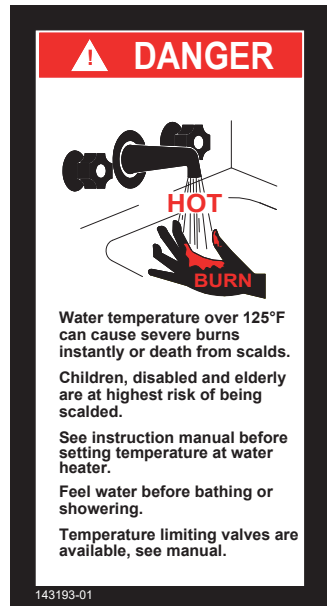

The product represent a burn hazard as it contains water of very high temperature stored under high pressure. Do not unscrew any pipe fittings or disconnect any components before ensuring it is safe to do so. Suitable safety clothing and protective equipment must be used when working on the product and its accessories. Parts of this equipment can become very hot during operation. Do not touch any surfaces unless it is ensured they are cool enough to avoid scalding or injury.



A safety label (see illustration, right) is present on the product and must not be removed, damaged or covered.







 This document should be kept in a suitable place where it is accessible for future reference.





1.2 Safety instructions for users

 WARNING	
	The overflow from the safety valve must NOT be sealed or plugged.
	The product must NOT be modified or changed from its original state.
	Children must NOT play with the product or go near it without supervision.
	Maintenance/settings must only be carried out by persons over 18 years of age, with sufficient technical understanding.





 CAUTION	
	The product must not be exposed to frost, over-pressure, over-voltage or chlorine treatment. See warranty provisions.
	Maintenance/settings must not be carried out by persons of diminished physical or mental capacity, unless they have been instructed in the correct use by someone responsible for their safety.

1.3 Safety instructions for installers

 WARNING	
	The overflow from any safety valve must NOT be blocked, sealed or plugged. A T&P safety valve is supplied with the product. The installation is not complete unless the supplied temperature and pressure relief valve (or other approved safety valve) is installed in the manner described in this manual. No valve or other components must be fitted between the safety valve and the storage tank. Installation must be performed by an approved installer.
	The discharge pipe from any safety device must be at least one pipe size larger than the nominal outlet size of the safety device (< 9m length). The discharge pipe must be pitched towards a suitable drain and be uninterrupted, undamaged and frost-free at all times.
	The relevant regulations and standards, and this installation manual, must be followed.

 CAUTION	
	The product must be placed in a room with a floor drain. The manufacturer assumes no responsibility whatsoever if this provision is not followed.
	The product must be properly aligned vertically and horizontally, on a floor or wall suitable for the total weight of the product when in operation. See table 2.3.
	The product must have a clearance for servicing of 50 cm in front of the product and 15 cm. above the highest point.

1.4 Installation restrictions

 WARNING	
	The fluid introduced into the coil must be water having a toxicity rating or Class of 1 as listed in Clinical Toxicology of Commercial Products (latest edition).
	The external heat source must be installed and operated in accordance with the manufacturer's instructions as well as those of the authority having jurisdiction.
	Any water treatment system connected to this product must be approved by the manufacturer. It must be ensured that any such system is properly operated and maintained.

2. PRODUCT DESCRIPTION

2.1 Product identification

Identification details for your product can be found on the type plate fixed to the product. The type plate contains details of the product, as well as other useful data. See Declaration of Conformity at www.osohotwater.com for more information.

OSO Hotwater AS is certified for

- Quality ISO 9001
- Environment ISO 14001
- Work environment ISO 45001
- Welding standard EN ISO 3834-2

2.2 Intended use

The Delta Coil - DC series is manufactured in stainless steel with a built-in stainless steel heating coil, and is designed for use as a buffer for tap water. The DC is designed for heating from a boiler or other suitable external energy source. The product is not intended for use in pool heating applications or for heating any other fluid than water. It is not intended for use in a gravity hot water heating system.

Any safety valve(s) used must be UL or CSA marked and conform to CSA or ASME (BPVC).

2.3 Technical data

OSO product no.	Product code:	Weight Kg.	Weight in operation - Kg.	Diameter x height mm	Standby heat loss - °F/h	Actual volume USG/L.
11015863	DC 030/120 - HX 0.64 m ²	31	145	Ø595 x 841	1.4	30/114
11015816	DC 040/150 - HX 0.80 m ²	36	180	Ø595 x 1001	1.1	40/150
11015817	DC 050/200 - HX 0.94 m ²	44	237	Ø595 x 1266	0.9	51/192
11015818	DC 075/300 - HX 1.33 m ²	58	339	Ø595 x 1746	1.0	74/280
11016096	DC 100/380 - HX 2.00 m ²	TBA	TBA	Ø595 x 2226	TBA	TBA
11016049	DC 119/450 - HX 2.55 m ²	109	530	Ø800 x 1628	1.4	111/421

2.4 Supplied safety equipment

This product is supplied with a T&P safety valve. The valve must be fitted to the product as described in this manual, and will open to relieve excess temperature or pressure which may develop inside the storage tank under certain conditions. The T&P safety valve is designed to release at 150 psi / 210°F.

Important: No valve or other components must be fitted between the T&P safety valve and the storage tank.

Any safety valve used with this product must comply to regulations in accordance with specifications shown under pt. 2.2.

The DC 100/380 is supplied with a center support foot to ensure optimal product stability in operation. For further information see pt. 3.2 and 3.9.

3. INSTALLATION INSTRUCTIONS

3.1 Products covered by these instructions:

- DC 030/120 - HX 0.64 m²
- DC 040/150 - HX 0.80 m²
- DC 050/200 - HX 0.94 m²
- DC 075/300 - HX 1.33 m²
- DC 100/380 - HX 2.00 m²
- DC 119/450 - HX 2.55 m²

3.2 Included in delivery

DC 030/120 to DC 100/380 only

Ref no.	Pcs.	Description
1	1	Storage tank with built-in coil
2	1	P&T safety valve 150psi / 210°F (supplied)
3	1	Sensor pocket
4	1	Installation manual (this document)
5	3	Adjustable feet (factory fitted)
6	1	Center support foot with base*

*Supplied with DC 100/380 only. Installation instructions, see pt. 3.9 on page 12.

IMPORTANT: The center support foot must be installed before filling the product with water.

3.3 Product dimensions

All dimensions in mm.

Product	A	B	C	D	E	F	Ø
DC 030/120	0-40	841	536	266	155	100	595
DC 040/150	0-40	1001	616	266	155	100	595
DC 050/200	0-40	1266	677	266	155	100	595
DC 075/300	0-40	1746	746	266	155	100	595
DC 100/380	0-40	2226	1107	266	155	100	595

Tolerance +/- 5 mm. (not dimension A).

Connection dimensions and description, see p. 10.

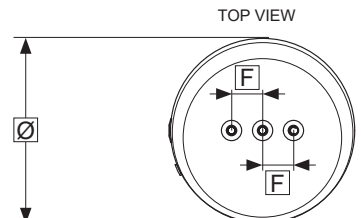
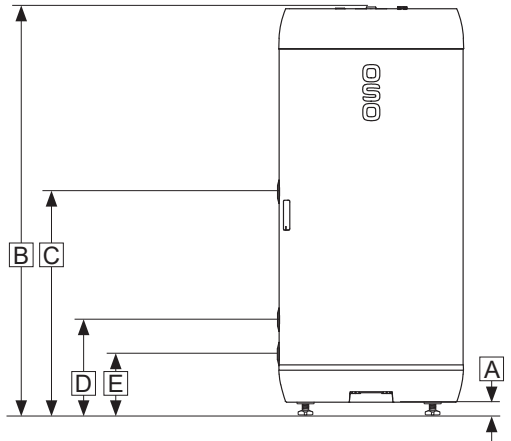
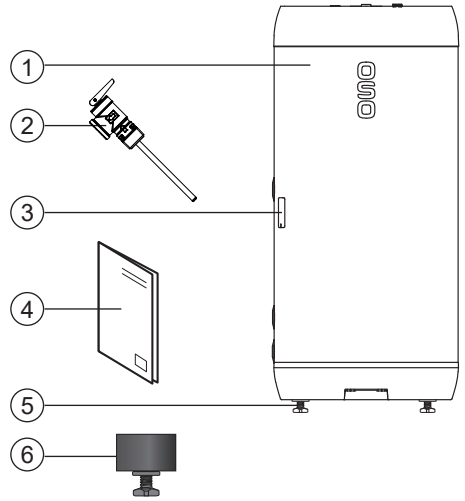

3.4 Included in delivery

DC 119/450 only

Ref no.	Pcs.	Description
1	1	Storage tank with built-in coil
2	1	P&T safety valve 150psi / 210°F (supplied)
3	1	Sensor pocket with strain relief (factory fitted)
4	1	Installation manual (this document)

3.5 Product dimensions

All dimensions in mm.

Product	A*	B	C	D	E	F	G	H	Ø
DC 119/450	1628	1555	1230	1120	770	320	260	51	800

Tolerance +/- 5 mm.

*Tolerance +50 / - 0 mm.

Angular tolerance +/- 1° (see 'top view').

Connection dimensions and description, see p. 11.

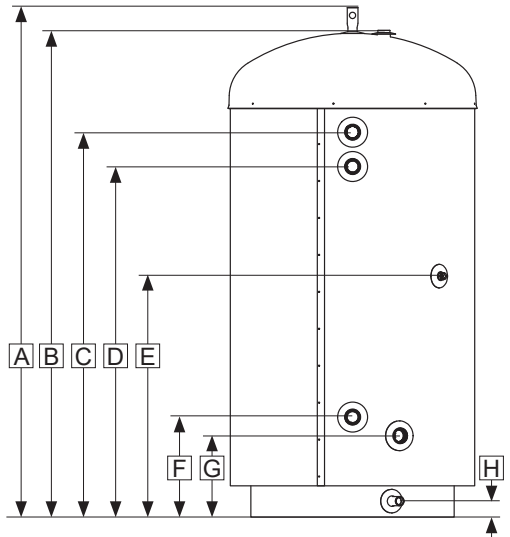
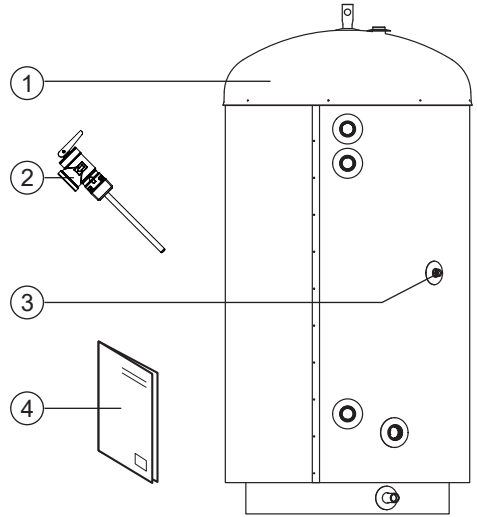

TOP VIEW

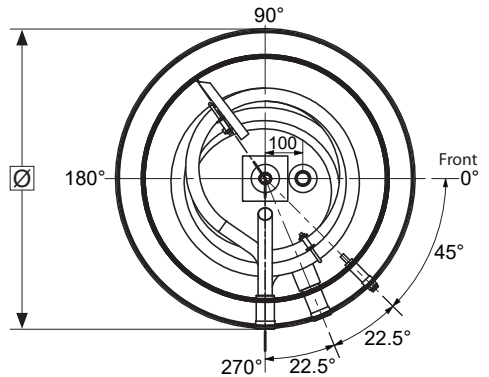

3.5.1 Delivery

The product must be transported carefully, with the packaging on. The DC 030/120 to 100/380 is delivered in a cardboard box which is equipped with handles. The handles should be used when lifting the product. See illustration.

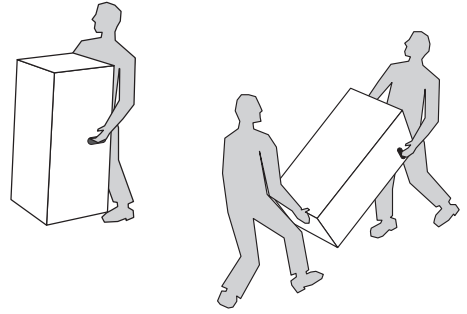

The DC 119/450 is fitted with a lifting lug (L) which must be used when lifting the product.

⚠ CAUTION

Pipe stubs, valves etc. must not be used to lift or handle the product as this could cause malfunctions.

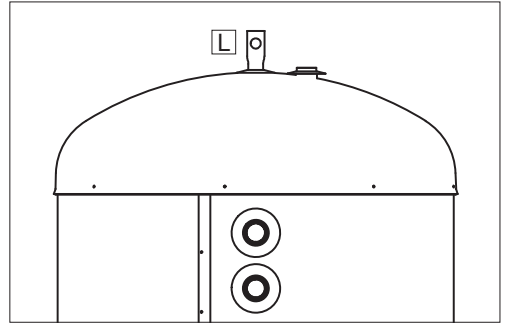

3.5.2 Temperature sensor installation

DC 030/120 to 100/380: The product is equipped with a temperature sensor bracket which allows installation of a 6 or 8 mm. temperature sensor. To install the temperature sensor follow the instructions below:

1. Remove temperature sensor bracket (A) from tank body by gripping it and pulling straight out.
2. Insert temperature sensor from external heat source (B) firmly into the appropriate grooves in the sensor bracket and place the temperature sensor cable in the cable slot (D). An 8 mm. sensor (shown) fits in the upper grooves (C) while a 6 mm. sensor fits in the lower groove (E).
3. Refit the sensor bracket into the tank body, ensuring the bracket is inserted fully to establish proper contact between the sensor and the stainless steel inner tank surface. Make sure the sensor cable is positioned properly in the cable slot (D) to avoid potential damage to the cable.

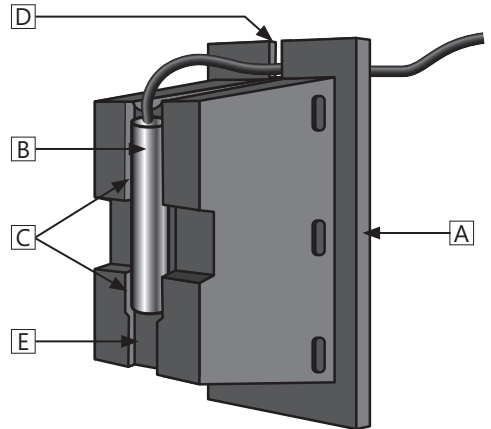

DC 119/450: The product is equipped with a temperature sensor pocket factory fitted in the tank, which allows installation of a Ø8 mm. temperature sensor. To install the temperature sensor follow the instructions below:

4. Unscrew the strain relief nut (F).
5. Insert temperature sensor from external heat source (G) fully into sensor pocket (H).
6. Thread the sensor wire (I) through the strain relief nut (F) and fit the nut back onto the strain relief base (J). Ensure the temperature sensor remains fully inserted into the sensor pocket before tightening the strain relief nut.
7. Tighten strain relief nut (F) by hand force only.

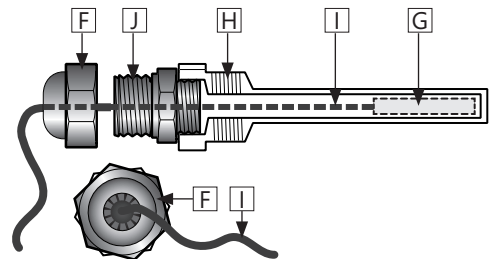

Temperature sensors are not supplied with the product.

3.5.3 Product clearance - cutaway view

The product must have a clearance for servicing of min. 50 cm in front of the product and min. 15 cm. above the highest point..See illustrations.

Upper cutaway view shows DC 030/120 to 100/380. Lower cutaway view shows DC 119/450.

3.5.4 Unpacking and positioning the product (DC 030/120 to 100/380 only)

1. Open the packaging and remove the protective plastic from the product.
2. The product is equipped with three factory-fitted adjustable feet, adjustable from 0-40 mm. Place the product carefully on its back, preferably on the cardboard packaging to avoid cosmetic damage.
3. Unscrew the adjustable feet at least 15 mm. from the bottom of the product (F).
4. Raise the product onto its feet, making sure that the feet are not exposed to oblique loads while the product is raised. This could damage the feet.
5. Place the product in a suitable place in the home, adjust the feet individually until the product stands firm and stable in plumb and level.
6. Follow the installation requirements shown in table 3.6.

3.5.5 Positioning the product (DC 119/450 only)

7. Position the product on a flat, level and even surface suitable for the weight of the product in operation.
8. Ensure the product is standing stable in plumb and level.
9. Follow the installation requirements shown in table 3.6.

3.6 Requirements for installation, location and positioning

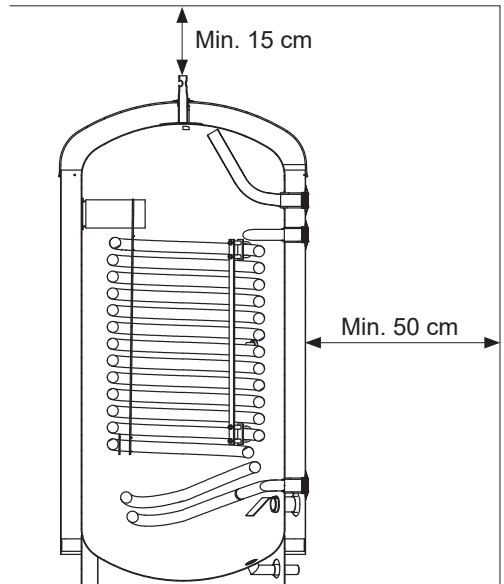
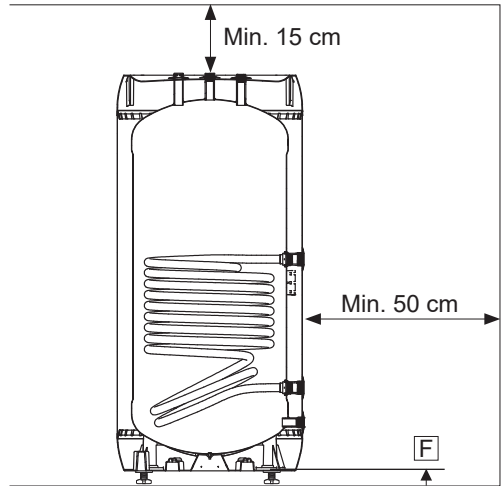

⚠ CAUTION

❗	The product must be placed in a room with a floor drain. The manufacturer assumes no responsibility whatsoever if this provision is not followed.
❗	The product must be placed in a dry and permanently frost-free position.
❗	The product must be properly aligned vertically and horizontally, on a floor or wall suitable for the total weight of the product when in operation. See table 2.3.
❗	The product must have a clearance for servicing of 50 cm in front of the product and 15 cm. above the highest point..See illustration.
❗	The product must be easily accessible for servicing and maintenance.

3.7 Pipe installation - DC 030/120 to 100/380

The product is designed to be permanently connected to the mains water supply. Approved pipes of the correct size must be used for installation. The relevant standards and regulations must be followed.

No.	Dimension	Connection description
1	3/4" BSP F	Auxiliary connection (plugged)
2	3/4" NPT F	Hot water outlet
3	3/4" NPT F	T&P pressure relief valve
4	1" NPT F	Coil connection upper - From boiler
5	Ø6 - Ø8 mm	Temperature sensor bracket
6	1" NPT F	Coil connection lower - To boiler
7	3/4" NPT F	Cold water inlet

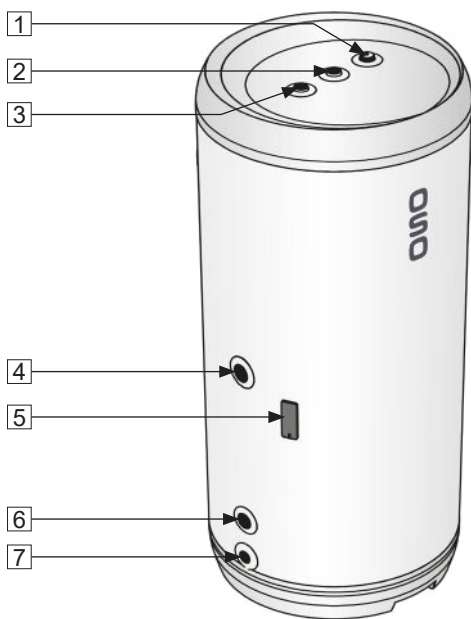

3.7.1 Incoming water pressure

The efficiency of the product depends on the incoming cold water pressure. The water pressure should be min. 2 bar and max. 6 bar throughout the day. If the maximum water pressure exceeds 6 bar in a 24-hour period, a pressure reduction valve and expansion vessel must be fitted.

3.7.2 Pipe fitting

Run a pipe of suitable size to the connections shown, and affix with suitable sealant. Unused connections must be plugged securely.

3.7.3 Fitting of overflow pipe

Overflow pipe (9) of suitable dimension is run to P&T safety valve;

- Connect to the overflow (8) of the P&T safety valve (3/4" female thread).
- The overflow pipe must be fitted uninterrupted, undamaged and frost-free pitched to a suitable drain.

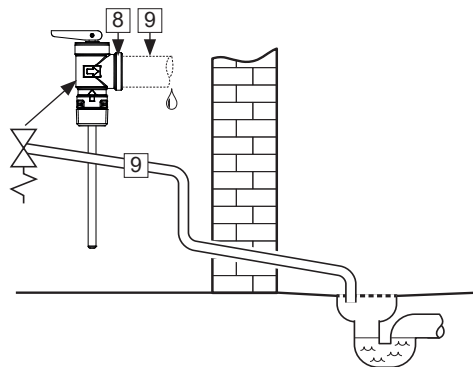

3.7.4 Pressure drop table - coil

Product info:		Pressure drop (mbar) at volume flow (water temperature above 50°C/122°F):								Cw value (m³/h):
Product	Coil surface m²	540 L/h (0,15L/s)	900 L/h (0,25 L/s)	1800 L/h (0,50 L/s)	2700 L/h (0,75 L/s)	3600 L/h (1,00L/s)	4500 L/h (1,25 L/s)	5400 L/h (1,50 L/s)	Flow @ 1bar pressure drop	
DC 030/120	0.64	9	20	69	137	240	350	491	8.9	
DC 040/150	0.80	10	22	76	152	267	391	561	8.0	
DC 050/200	0.94	10	24	90	184	320	474	680	7.2	
DC 075/300	1.33	15	38	140	280	487	715	1032	5.8	
DC 100/380	2.00	22	58	218	434	758	1126	1605	5.0	

3.8 Pipe installation - DC 119/450

The product is designed to be permanently connected to the mains water supply. Approved pipes of the correct size must be used for installation. The relevant standards and regulations must be followed.

No.	Dimension	Connection description
1	-	Lifting lug
2	1" NPT F	T&P pressure relief valve
3	1 1/4" NPT F	Hot water outlet
4	1 1/4" NPT F	Coil connection upper - From boiler
5	-	Thermostat pocket
6	1 1/4" NPT F	Coil connection lower - To boiler
7	1 1/4" NPT F	Cold water inlet
8	3/4" NPT F	Drain (plugged)

3.8.1 Incoming water pressure

The efficiency of the product depends on the incoming cold water pressure. The water pressure should be min. 2 bar and max. 6 bar throughout the day. If the maximum water pressure exceeds 6 bar in a 24-hour period, a pressure reduction valve and expansion vessel must be fitted.

3.8.2 Pipe fitting

Run a pipe of suitable size to the connections shown, and affix with suitable sealant. Unused connections must be plugged securely.

3.8.3 Fitting of overflow pipe

Overflow pipe (10) of suitable dimension is run to P&T safety valve;

- Connect to the overflow (9) of the P&T safety valve (3/4" female thread).
- The overflow pipe must be fitted uninterrupted, undamaged and frost-free pitched to a suitable drain.

3.8.4 Pressure drop table - coil

Product info:		Pressure drop (mbar) at volume flow (water temperature above 50°C/122°F):							Cw value (m³/h):
Product	Coil surface m²	540 L/h (0,15L/s)	900 L/h (0,25 L/s)	1800 L/h (0,50 L/s)	2700 L/h (0,75 L/s)	3600 L/h (1,00L/s)	4500 L/h (1,25 L/s)	5400 L/h (1,50 L/s)	Flow @ 1bar pressure drop
DC 119/450	2.55	27	74	282	561	980	1463	2075	4.0

3.8.5 Fitting instructions - all volumes

⚠ CAUTION	
❗	The product must be placed in a room with a floor drain. The manufacturer assumes no responsibility whatsoever if this provision is not followed.
❗	The product must be properly aligned vertically and horizontally, on a floor or wall suitable for the total weight of the product when in operation. See table 2.3.
❗	The product must have a clearance for servicing of 50 cm in front of the product and 15 cm. above the highest point..See illustration on page 9.

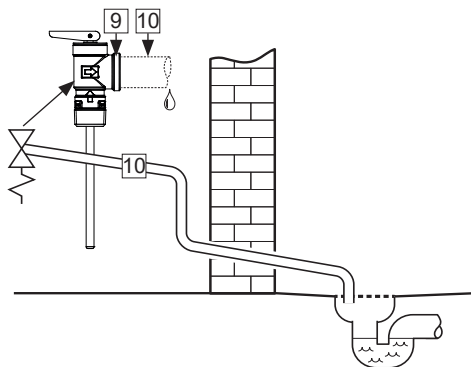
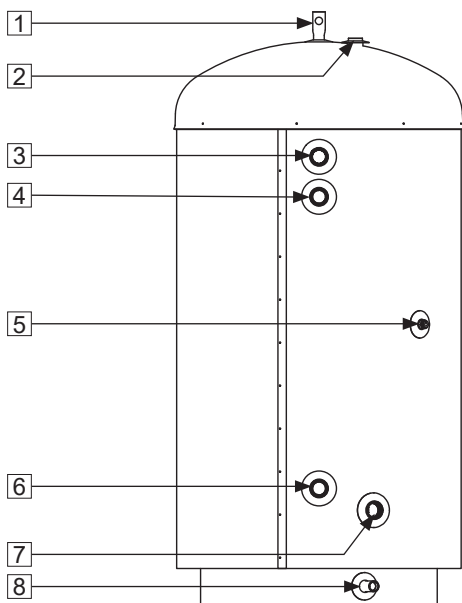

3.9 Installation of the center support foot

(DC 100/380 only)

- A. Unpack the product and lay it on its side. Use the packaging cardboard as a substrate, and take care to avoid cosmetic damage to the product.
- B. Two adhesive pads are included with the center support foot. Remove the protective paper on one side and fit the adhesive pads as shown (1).
- C. Remove the second protective paper on the adhesive pads and fit the center support (2) with its foot (3) in the center recess (5) in the bottom of the product. Press the center support firmly into place.
- D. Unscrew the support foot (3) to the desired height (min. 15 mm. is recommended). Raise the boiler so that it stands on the foot (3) of the center support while ensuring the foot is not exposed to oblique loads when raising the product. Unscrew the factory fitted feet (4) slightly to enable easy access for later adjustment.
- E. Place the product in the desired position in the room.
- F. Adjust the three factory fitted outer feet (4) until the product is plumb and level. The middle support foot **MUST** be in full contact with the floor after the adjustment.
- G. Install pipes to the product and fill up with water according to the pipe installation and filling instructions in this manual.

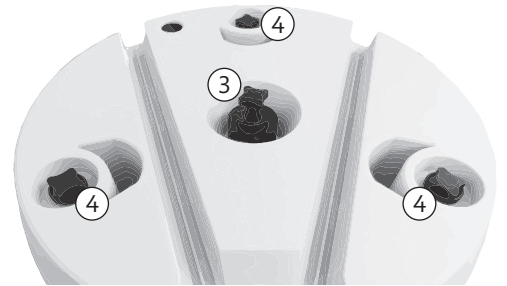
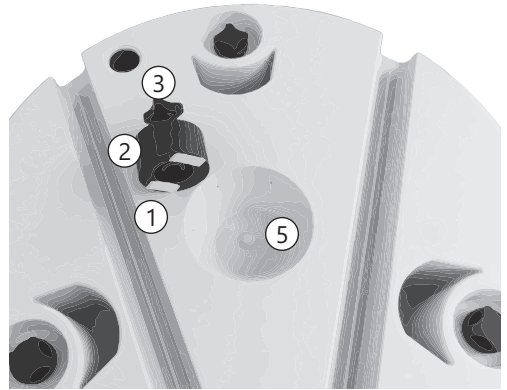

4. INITIAL COMMISSIONING

4.1 Filling with water

First check that all pipes are connected correctly. Then fill the tank according to the requirements of the system. Make sure that the tank is vented during filling to prevent air pockets. The tank must be room temperature before filling. .

4.2 Control points

1. Check that all pipe connections to/from the product are tight and not leaking.
2. Check that any overflow pipe from the P&T safety valve is uninterrupted, undamaged and frost-free with a fall to the drain.
3. Check that the product is standing firmly vertically and horizontally.

4.3 Emptying of water

⚠ WARNING

The water temperature in the product can be 75°C and could cause scalding. Before emptying, a hot tap should be opened to the max. pressure/temperature for min. 3 minutes.

1. Shut off incoming cold water supply.
2. Open a hot tap to the maximum – leave open (prevents vacuum).
3. The DC 030/120 to 100/380 is emptied by disconnecting the cold water supply pipe and draining the product through the cold water supply connection. See pt. 3.7.
4. The DC 119/450 is drained through the factory fitted drain connection. See pt. 3.8.

After emptying, refit the cold water supply pipe/ close the drain connection. Close all open taps.

Draining the coil: Turn off external energy source, see instructions supplied with the product. Disconnect flow/return pipes, drain coil. Use compressed air to fully empty the coil. Refit pipes and refill the system with water before restarting.

4.4 Handover to end-user

THE INSTALLER MUST:

Brief the end-user on safety and maintenance instructions.

Brief the end-user on settings and emptying the product.

Hand this installation manual over to the end-user.

Enter contact details in table 6.2 on page 14 in this manual.

5. USER GUIDE

5.1 Annual inspection

All components fitted in or to the product must be inspected annually. Inspection must be performed by a person older than 18 years of age, with appropriate technical qualifications. Annual inspection includes:

- Checking all connections for leaks. Tighten or maintain properly if required. Do not operate the product with leaking pipes or connections, as this can result in severe damage.
- Inspection of safety valve function and operation, see pt. 5.2.
- Inspection of boiler/external heat source, see documentation supplied with the product.

5.2 Maintenance

MAINTENANCE INSTRUCTIONS

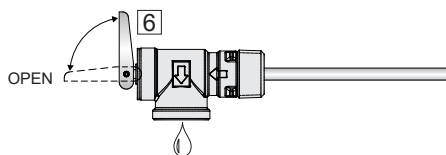

⚠	Maintenance must be carried out by persons over 18 years of age, with sufficient understanding.
⚠	Annual inspection of P&T safety valve:
-	Open valve for 1 min. by turning handle (6) approx. 90 degrees to the open position as shown in illustration.
-	Visually check that the water is flowing freely from the overflow to the drain.
-	YES = OK. Close the valve by turning the handle (6) back to the closed position.
-	NO = NOT OK. Disconnect power supply / shut off water supply. Contact installer.

6. TROUBLESHOOTING

6.1 Faults and fixes

If problems arise when the product is in use, check for possible faults and fixes in the table. If you are unsure what is wrong, contact the

installer (see product type plate) or OSO Hot-water Inc. - see section 7.1.

TROUBLESHOOTING		
Problem	Possible cause of fault	Possible solution
There is leakage/dripping from the safety valve/ there is often water on the floor by the cylinder in the morning	Pressure reduction valve, water meter or blocked non-return valve on the water intake.	Fit AX expansion vessel which absorbs expansion during heating, and fit pressure reduction valve for stable water pressure inside the system. The pressure reduction valve is adjusted in according to the pressure in the expansion vessel. Contact authorized installer.
	Water pressure into the system is too high.	
No hot water	The safety valve is worn or there are particles stuck between the membrane and the valve seat because the water is dirty	Try to flush with water through the safety valve. Open valve for approx. 1 minute. See section 5.2. If the valve still leaks, it must be replaced. Contact auth. installer.
	Power supply interrupted or other fault with boiler/external heat source.	
Not enough hot water	Leak in hot water pipe	Check the boiler/external heat source.
	High consumption in the system.	
Not enough hot water	High consumption in the system.	Verify as follows: a) close the water supply, b) wait 2-3 hours, c) feel the tank to see whether it is hot. If so, there is a leak in the hot water pipe or elsewhere. Contact authorized installer.
Not high enough water temperature	Insufficient effect from boiler/external heat source.	Switch to a larger OSO water heater or increase the effect from the boiler/external heat source. Contact authorized installer.
Not high enough water temperature	Insufficient effect from boiler/external heat source.	Check the boiler/external heat source.
Long time before the hot water reaches the tap	Long stretch of pipe from water heater to tap.	Fit circulation pipe or heating cable to HW supply pipe. Or fit an auxiliary heater by the tap. Contact authorized installer.
Knocking in the pipes when the hot tap is closed	Large pressure increase when the tap is closed quickly.	Fit AX expansion vessel if troublesome. Contact auth. installer.

6.2 Contact details - installer

CONTACT INFORMATION	
Installed by (company):	
Company address:	
Company telephone:	
Company email:	
Installer name:	
Installation date:	

7. WARRANTY CONDITIONS - applies to Canada only

1. Scope

OSO Hotwater AS (hereinafter called OSO) warrants for 7 years from the date of purchase, that the Product will: i) conform to OSO specification, ii) be free from defects in materials and workmanship, subject to conditions below. All components carry a 2-year warranty. The conditions and limitations set out below shall apply.

2. Coverage

If a defect arises and a valid claim is received within the statutory warranty period, at its option and to the extent permitted by law, OSO shall either; i) repair the defect, or; ii) replace the product with a product that is identical or similar in function, or; iii) refund the purchase price.

If a defect arises and a valid claim is received after the statutory warranty period has expired, but within the extended warranty period, OSO will supply a product that is identical or similar in function. OSO will in such cases not cover any other associated costs.

Any exchanged Product or component will become the legal property of OSO. Any valid claim or service does not extend the original warranty. The replacement Product or part does not carry a new warranty.

3. Conditions

The Product is manufactured to suit most public water supplies. However, there are certain water chemistries (outlined below) that can have a detrimental effect on the Product and its life expectancy. If there are uncertainties regarding water quality, the local water supply authority can supply the necessary data. The warranty applies only if the conditions set out below are met in full:

- The Product has been installed by a professional installer, in accordance with the instructions in the installation manual and all relevant Codes of Practice and Regulations in force at the time of installation.
- The Product has not been modified in any way, tampered with or subjected to misuse and no factory fitted parts have been removed for unauthorized repair or replacement.
- The product has been connected to the public power grid and it has not been connected to an external power supply control unit not approved by OSO.
- The Product has only been connected to a domestic mains water supply in compliance with the Guidelines for Canadian Drinking Water Quality by Health Canada, latest version. The water should not be aggressive, i.e. the water chemistry shall comply with the following:
 - Chloride < 250 mg / L
 - Electric Conductivity (EC) @25°C < 750 uS / cm

- Saturation Index (LSI) @80°C > - 1,0 / < 0,8
- pH level > 6,0 / < 9,5

- The cylinder/immersion heater has not been exposed to hardness levels exceeding 10°dH (180 ppm CaCO₃). A water softener is recommended in such cases.
- Any disinfection has been carried out without affecting the Product in any way whatsoever. The Product shall be isolated from any system chemical disinfecting.
- The Product has been in regular use from the date of installation. If the Product is not intended to be used for 60 days or more, it must be drained.
- Service and/or repair shall be done according to the installation manual and all relevant codes of practice. Any replacement parts used shall be original OSO spare parts.
- Any third-party costs associated with any claim has been authorized in advance by OSO in writing.
- The purchase invoice and/or installation invoice, a water sample as well as the defective product is made available to OSO upon request.

Failure to follow these instructions and conditions may result in product failure, and water escaping from the Product.

4. Limitations

The warranty does not cover:

- Any fault or costs arising from incorrect installation, incorrect application, lack of regular maintenance in accordance with the installation manual, neglect, accidental or malicious damage, misuse, any alteration, tampering or repair carried out by a non-professional, any fault arising from the tampering with or removal of any factory fitted safety components or measures.
- Any consequential damage or any indirect loss caused by any failure or malfunction of the Product whatsoever.
- Any pipework or any equipment connected to the Product.
- The effects of frost, lightning, voltage variation, lack of water, connecting to a non approved external power supply control unit, dry boiling, excess pressure or chlorination procedures.
- The effects of stagnant (de-aerated) water if the Product has been left unused for more than 60 days consecutively.
- Damage caused during transportation. Buyer shall give the carrier notice of such damage.
- Costs arising if the Product is not immediately accessible for servicing.

These warranties do not affect the Buyer's statutory rights.

7.1 Customer service

In case of problems that cannot be resolved with the aid of the troubleshooting guide in this installation manual, contact either:

A) The installer who supplied the product.

B) OSO Hotwater Inc.: Tel.: +1 (902) 478-7545

Email: tech.canada@osohotwater.com

Web: www.osohotwater.ca

8. REMOVING THE PRODUCT

8.1 Removal

- A) Disconnect the power supply.
- B) Shut off incoming cold water supply.
- C) Empty the product of water – see section 4.4.
- D) Disconnect all pipes.
- E) The product can now be removed.

8.2 Returns scheme

This product is recyclable and should be taken to the environmental recycling centre. If the product is to be replaced with a new one, the installer can take the old cylinder away for recycling.

OSO

HOTWATER

OSO Hotwater AS

Industriveien 1
3300 Hokksund - Norway
Tel: + 47 32 25 00 00
oso@oso.no
www.osohotwater.com